

nquiringminds

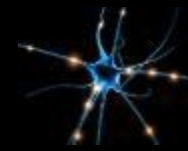

Open Source

Context-aware applications: industry landscape and commercial opportunities

This talk will give an overview of projects (mobile and non mobile) that are opening up the context-aware opportunities, as well as the significant challenges, security and privacy as always being pre-eminent, that need to be addressed. We shall look at the dynamics of the distinct vertical industries of mobile, PC, home media, automotive, that are principal focuses of webinos, and the combined opportunity that sharing context information horizontally across the classic silos, offers to application developers and service providers. We shall examine how the effective use of open source can be used to drive innovation in this space.

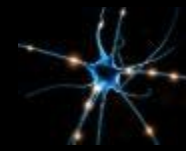

Credentials



Device APIs and Policy Working Group



DORLING KINDERSLEY
www.dk.com



Experience

Negotiating IPR Licensing
Governance

Recruiting contributors -
ecosystem building

Managing communities

Open Source Exploitation

Managing development

Venture Capital investment
and due diligence

Corporate (+academic)
joint ventures

Tools

Customers



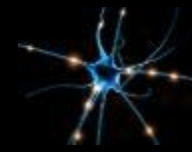

Request for input

- Open Source – Sustainable Development
- <http://webinos.org/archives/979> - blog outreach
- How do you create a successful open source project –
How to you maintain balance
 - What are the theoretical drivers for OSS
 - What are the commercial business models and motivations
 - What are the parameters that define a successful project
- Webinos 2.6 Release – Formal recommendations



nquiringminds

BACKGROUND

Context is:

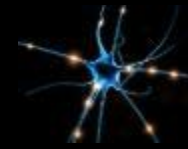

nquiringminds

Wikipedia: Context awareness is defined complementary to location awareness. Whereas location may serve as a determinant for resident processes, context may be applied more flexibly with mobile computing with any moving entities, especially with bearers of smart communicators. Context awareness originated as a term from ubiquitous computing or as so-called pervasive computing which sought to deal with linking changes in the environment with computer systems, which are otherwise static. Although it originated as a computer science term, it has also been applied to business theory in relation to business process management issue

http://en.wikipedia.org/wiki/Context_awareness

Context is for:

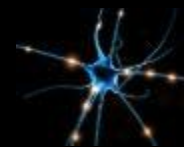

nquiringminds

Nicks: commercial interpretation

Computation and refinement of Bayesian probabilities to augment existing processes

Examples

- Amazon: If you like [Harry Potter] you are n% likely to [buy Chic lit]
- Telephony: If you are [at work] you are n% likely to [take a call from your cousin]
- Security: If [your friend has installed an application] you are n% likely to [trust it]
- Health: if the [humidity is over X] then you are N% likely to [have an asthma attack]
- UI: if the [editing a diagram] then you are N% likely to [select copy and paste menu item]



nquirmginds

Landscape

Some examples of the diverse uses of
context



nquiringminds

CONTEXT PHONE



ContextPhone

- <http://www.cs.helsinki.fi/group/context/>
- Live from 2002-2005
- Fantastic source of Symbian code – open source GNU General Public License (GPL)





ContextPhone: Description

- **Sensors:** are used to acquire context data from different sources, such as location (cell identifier and GPS) or phone usage.
- **Communications:** provide connections to services in the outside world via standard Internet protocols using GPRS, Bluetooth transfers, short messages (SMS) and multimedia messages (MMS). The communication channels can be used, e.g., to share presence information (Jabber) or to obtain sensor data (GPS over Bluetooth).
- **Customizable:** versions of built-in applications} are provided, in particular for the Contacts and Recent call list, to seamlessly replace the original ones.
- **System services:** provide facilities for automatic starting of background services, error logging and recovery as well as status display.

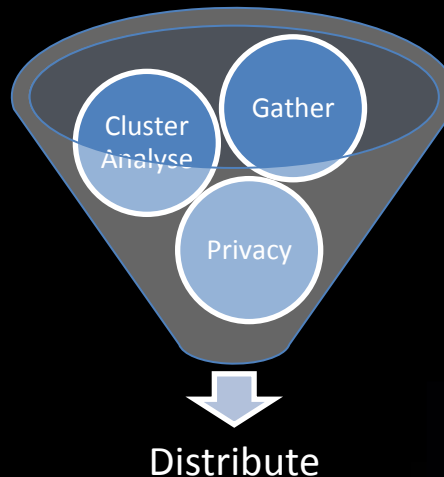

Context phone: Data Gathered

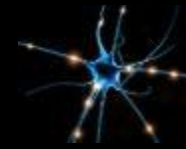

nquiringminds

Location
Network, area and cellid
No external topological information, nor semantics
Both interesting topics on their own
Chosen prole
Ambient sounds
at least sound level
maybe sound pattern recognition?
Bluetooth environment

Calendar events
Category (like meeting, leisure, reminder)
Location
Description (supplied by user)
Contacts
Call and SMS data
All with date and time

Descriptions given for the whole context (e.g. in a concert, at work) or to parts (place names)
Either written free text, selected from a predened (or user-dened) list, or spoken
Balance between ease of input, storage requirements, exibility

Light level
Distance sensor
Temperature
More detailed network information (other nearby base stations, distance to base station)

GPS location (with matchbox size sensor at 400e)
Bluetooth based location (tags/phones/whatever in some more local areas)
Accelometer and tilt sensors (maybe not very feasible)

Principles of Privacy aware (context) systems

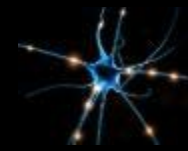

inquiringminds

Marc Langheinrich, Privacy by Design Principles of Privacy-Aware Ubiquitous Systems, Ubicomp 2001 Proceedings

- Openness and transparency: subject aware
- Individual participation: subject can see and modify records
- Collection limitation: not excessive for purpose
- Data quality: relevant, correct and up-to-date
- Use limitation: only for stated purposes, access controls
- Reasonable security: relative to data collected
- Accountability: subject able to verify compliance

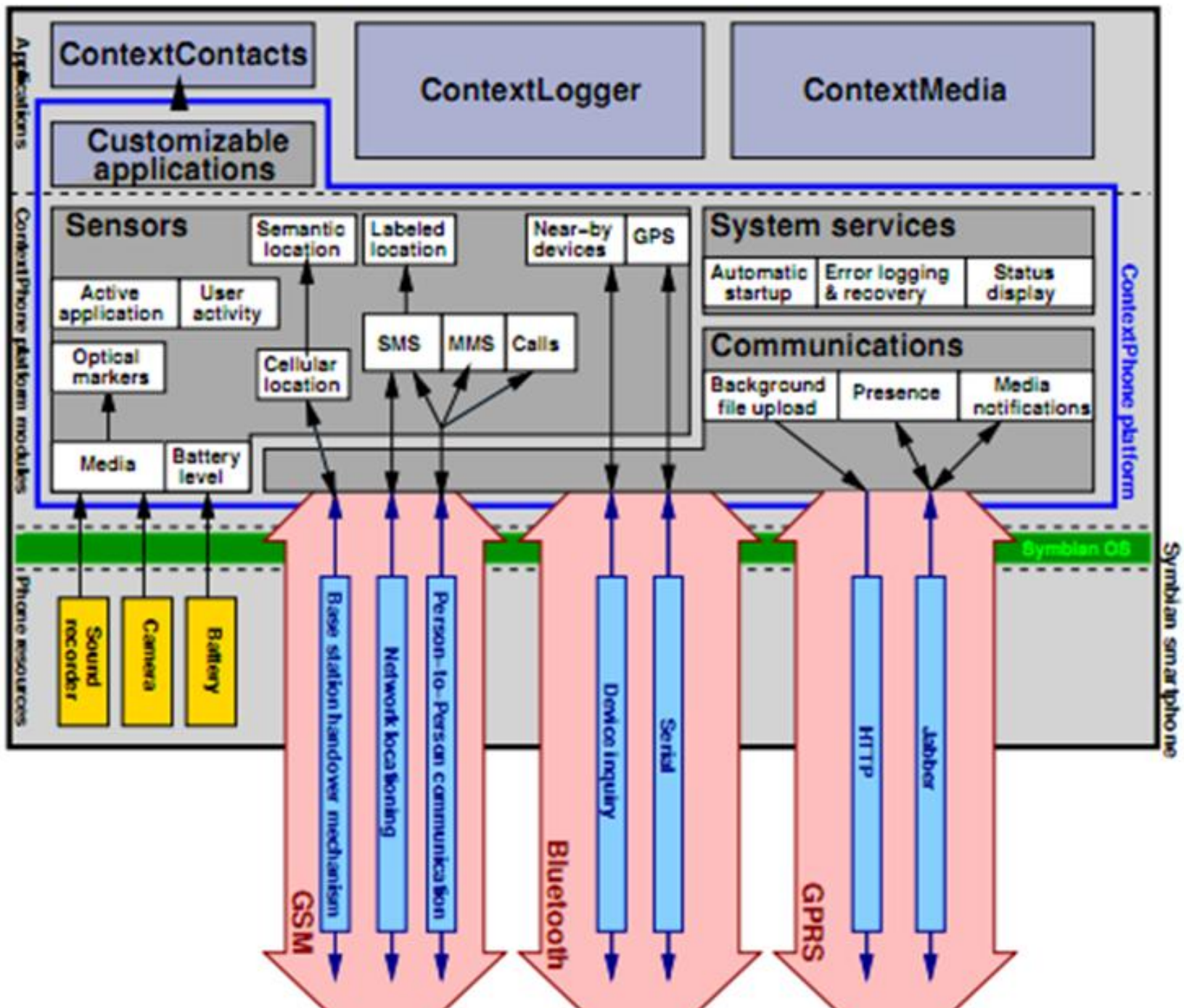

Consent model for ContextPhone



- Research OSS project
- Consent on application installation
- In App privacy
- Classic mutual consent Presence controls

Because is single device and preceded social networks
- a more simple privacy model

Commercial model for ContextPhone



- Originally university research project
- Evolution of ContextPhone after the Context project
- Since 2006, Jaiku Ltd. has developed commercial mobile presence services based on ContextPhone technology and application prototypes (see below).
- Breaking: Google Acquires Jaiku, Why Not Twitter?
- Since October 2007, Jaiku is part of Google.



nquiringminds

GOOGLE ANALYTICS

What does Google Analytics know about you



nquiringminds

- Where you are physically
- What device you are on
- What browser you are using
- What type of network you are on
- What operator you use
- What websites you have visited
- How long you have been on a website
- Where your mouse is hovering

Things GA work out about you



- Who you are – using biometric ?
- Where you have been - typical travel patterns
- What your interests are
- How you navigate a website
- How effective an advert is
- Which site you came from
- Which site you click on next

Consent model for Google Analytics

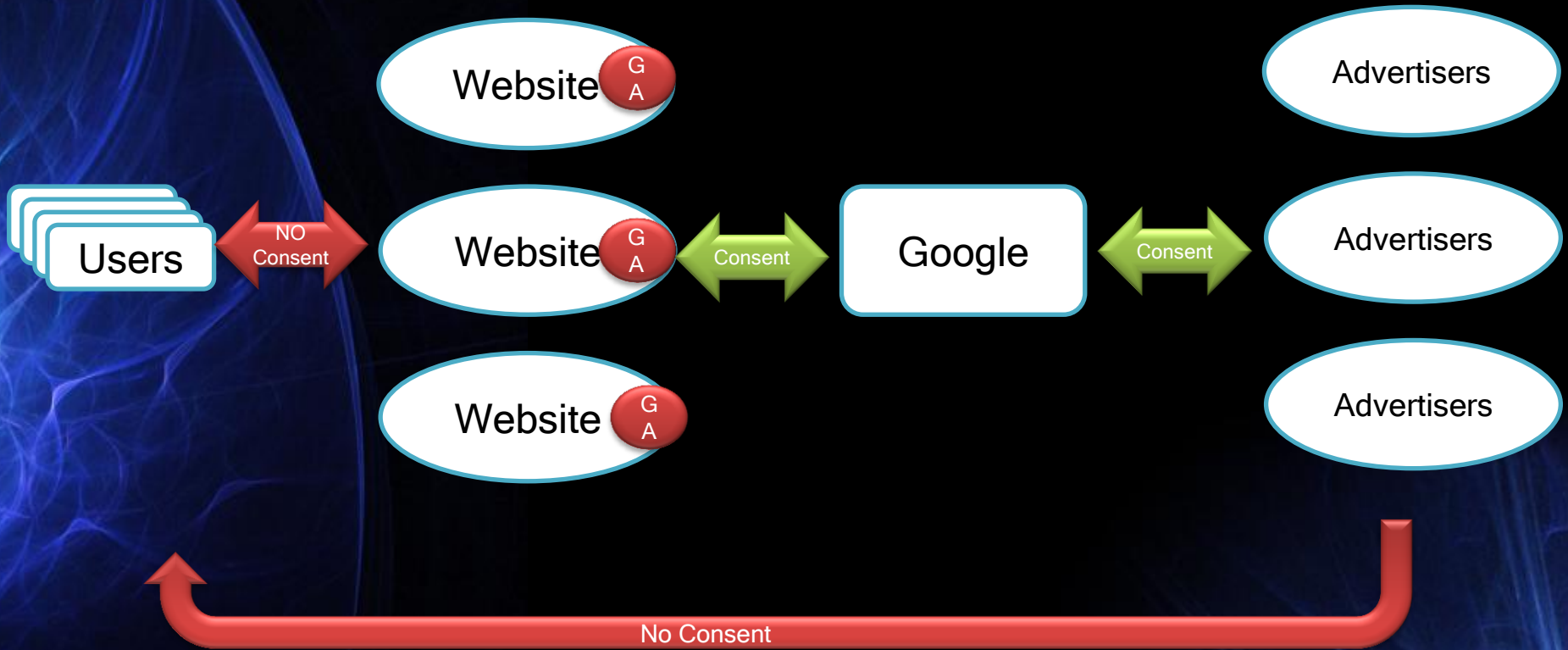

Do-not-track DNT



nquiringminds



- <http://donottrack.us/>
- <http://www.zdnet.co.uk/news/security-management/2011/06/22/eu-warns-web-firms-over-do-not-track-timescale-40093187/>
- RIPA - Under the [proposed amendments](#) (PDF), any business carrying out interception to provide 'value-added services' will require the consent of the sender and intended recipient of the communication.

Commercialisation model for Google Analytics

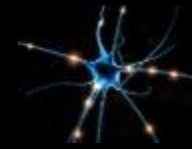

nquiringminds

- Google sells adverts
- Rich contextual information is provided to help you determine value
- Advert price is determined by an invisible algorithm
- Users “bid” on keywords
- Context simply provides “information” to help you decide you own bid
- Price is not tied to effectiveness



nquiringminds

PAL PROJECT

Personal and Social Communication Services for Health and Lifestyle Monitoring

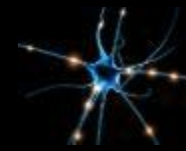

nquiringminds

- <http://palproject.org.uk/>
- Usecase: The development of the communication environment takes a two-pronged approach, by considering the impact that future healthcare services, described through our scenarios, pose on *evolutionary* (i.e., IP-based) and *exploratory* (i.e., pub/sub solutions developed in EU-funded project [PSIRP](#)) infrastructure solutions. Building on work performed in the TSB-funded [HIPNet](#) project, innovative traffic engineering concepts will be developed and enhanced to ensure the end-to-end integrity of a connection for a user both at home and away from home, through performing network selection modelling and algorithm development for predicting handover instances and deciding how and when to handover. We will also investigate effective methods for dynamic traffic engineering or service adaptation with the ability to demonstrate session robustness even in the presence of excessive background traffic. The concept of information-centric networking (IN) currently developed in the EU-funded project [PSIRP](#) will be studied with the potential of using available resources better, of reacting more dynamically to changes in the environment and in user behaviour, and of simplifying information governance in the network layers (e.g., through policy-based information flow selection). Prototype solutions will demonstrate the results within the existing HIPNet-based infrastructure.

Which means:

- Collate information from different devices, using optimal network routing
 - E.g. personal: heart monitor, room: air quality monitor, in-car: temperature monitor; TV: what are you watching; PC: what are you browsing
- Secure end to end collation of relevant data
- Place under user control to be shared with trusted parties (GP)

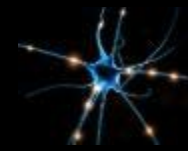

PAL diagram

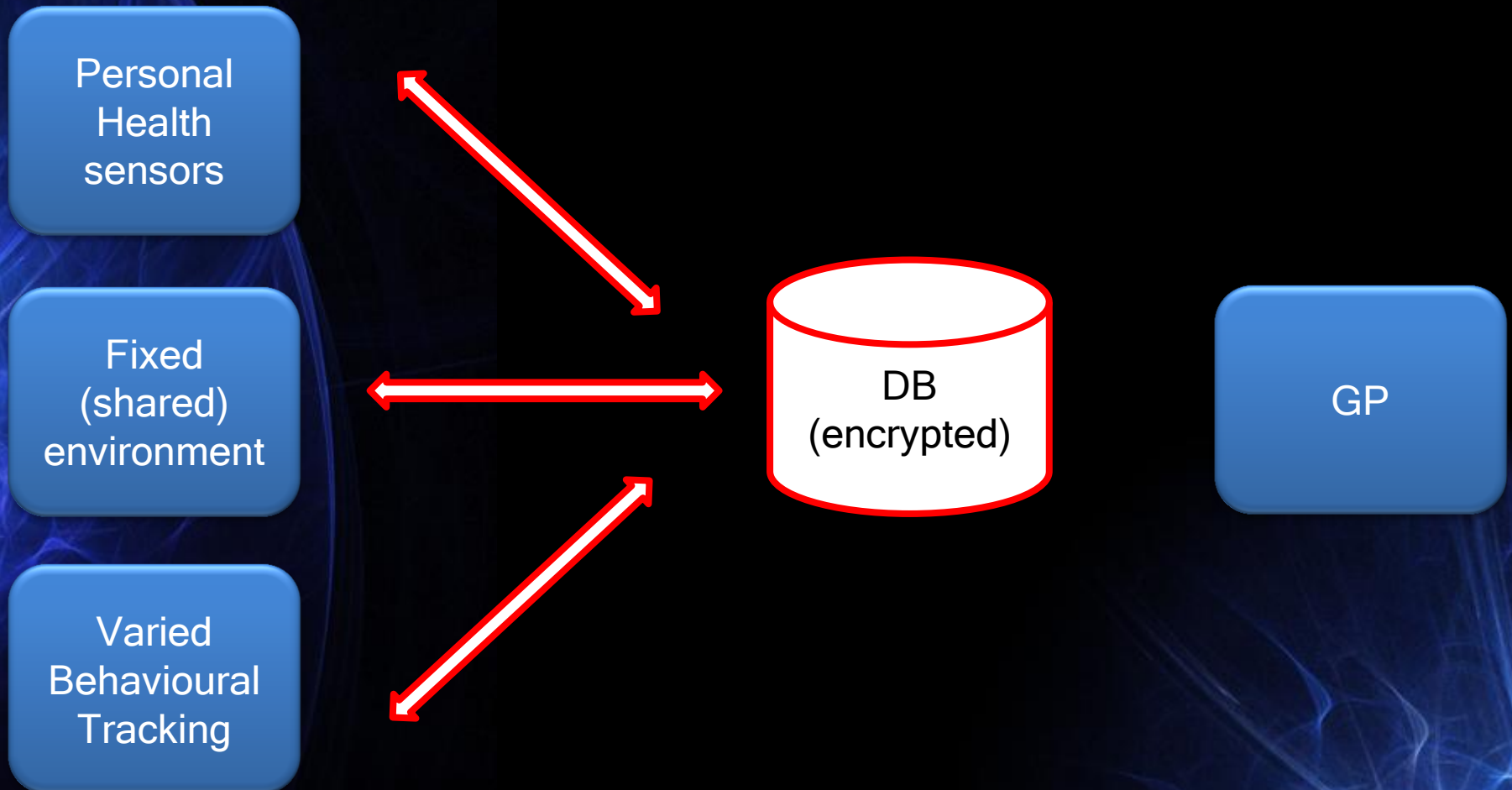

PAL: Consent and Commercials



- R&D project
- Consent:
 - user opt in.
 - Trusted intermediaries and
- Commercials
 -



nquiringminds

WHY OPEN SOURCE



Why Open Source

- Rapid market penetration
- Avoids closed ecosystems
- Encourages interoperability
- Compatible with “user controlled” data models



nquiringminds

WEBINOS



Use Case Family: Context Awareness

- Support application behaviour based on:
 - Device Context
 - Event Based Context
 - Devices in close Physical Proximity
 - Devices in “close” Social Proximity
- Obtaining Context Information through Sensors and Automated Data sources
- Finding and using the context information of local and remote Devices
- Discovering and Updating Context Information of a Shared Capability
- Publicity and privacy of Context Information

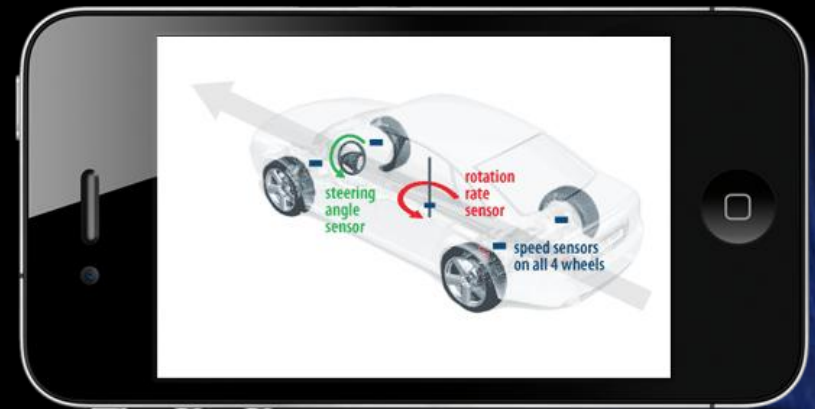

5 Verticals: Challenges and Opportunity

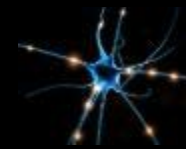

nquiringminds

Each Device type has a different business model, different ecosystem, different physical owner, different security model



Subsidised handsets
Controlled app ecosystems

Open app ecosystems

Advertising driven model
OR POD

High margin devices (media)
OR
Invisible black boxes

Combining the data across device types

required
 Service/App can see
 AuthN + Policy info

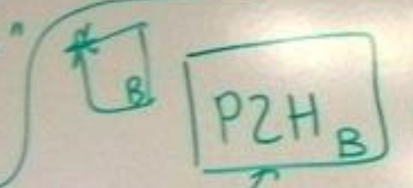

Local
 Case

Remote case
 out of scope
 look into
 social media
 integration

Initialising
 PZH

Intercept
 registration process.
 must be a secure
 channel + a trusted
 endpoint.
 SSL web registration session

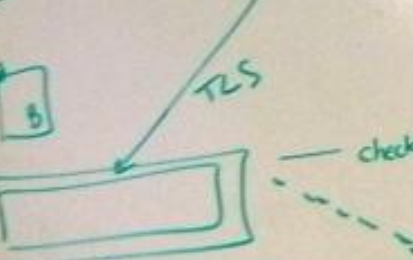

check Device (AuthN key, A ID)



may be
 multiple
 IDs
 FBoot
 Phone No.
 Twitter

2. device authentication
 PZH

(User is Authenticated)
 get AuthN Info

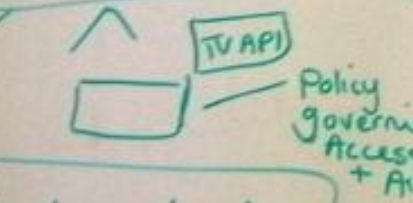

Policy governing
 Access + AuthN.

(A phone, A Facebook)

authenticate (N)
 check()

Authentication level
 must happen
 same time

PZH acts as
 Signing authority
 for device certificates.

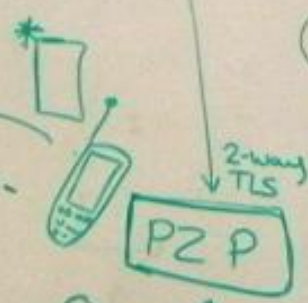

Joining Zones
 Initial registration

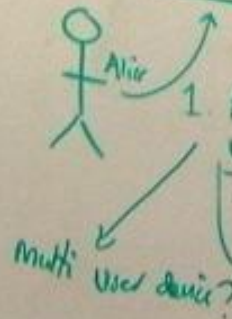

check Privilege() API

Access to
 Credentials
 on PZH

Case 2 - Certificate
 expiry, revocation.

Multi User device?

User
 time since
 authN
 device opinion?
 Method

Architectural Elements



nquiringminds

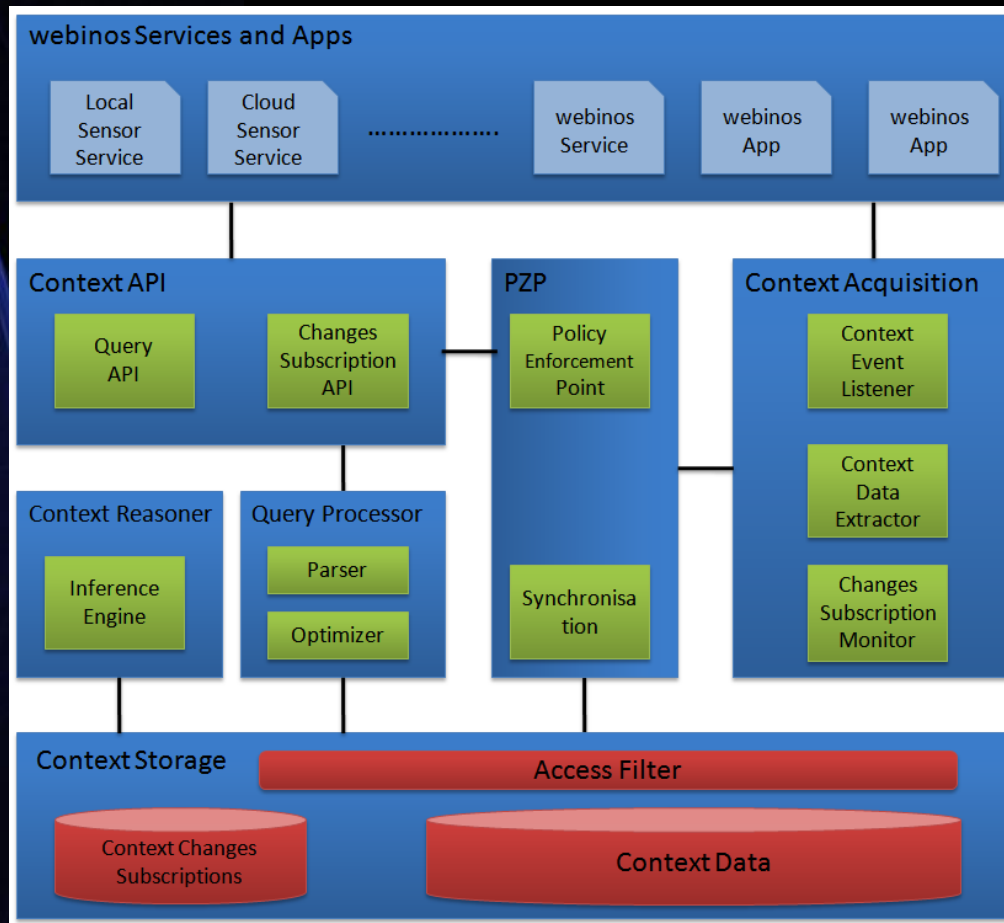

Data Design

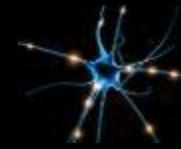

inquiringminds

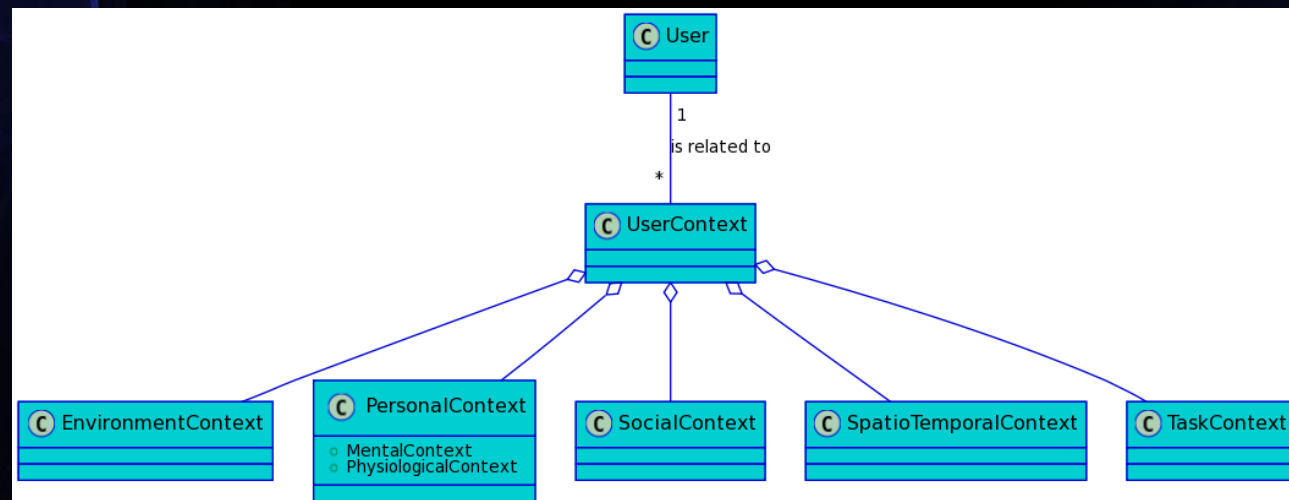
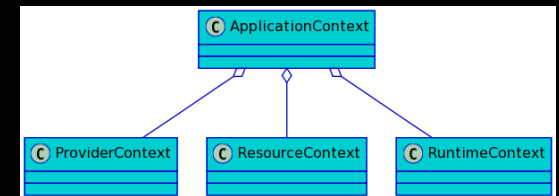
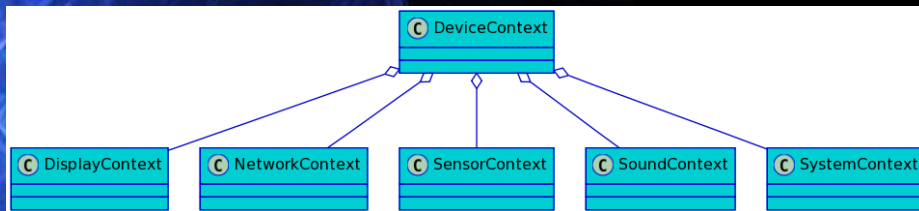
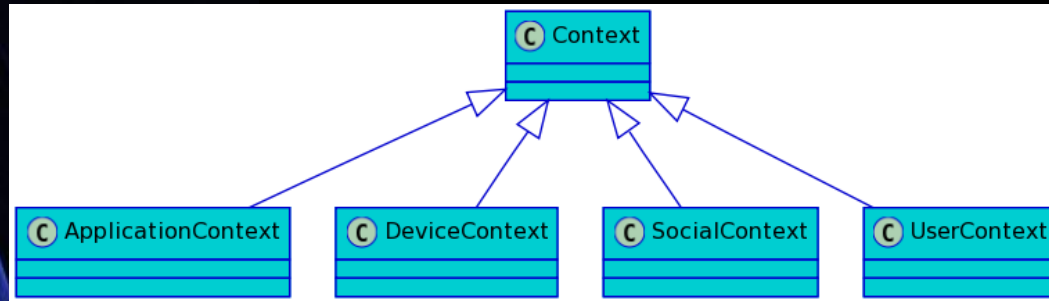

Webinos Architecture



nquiringminds

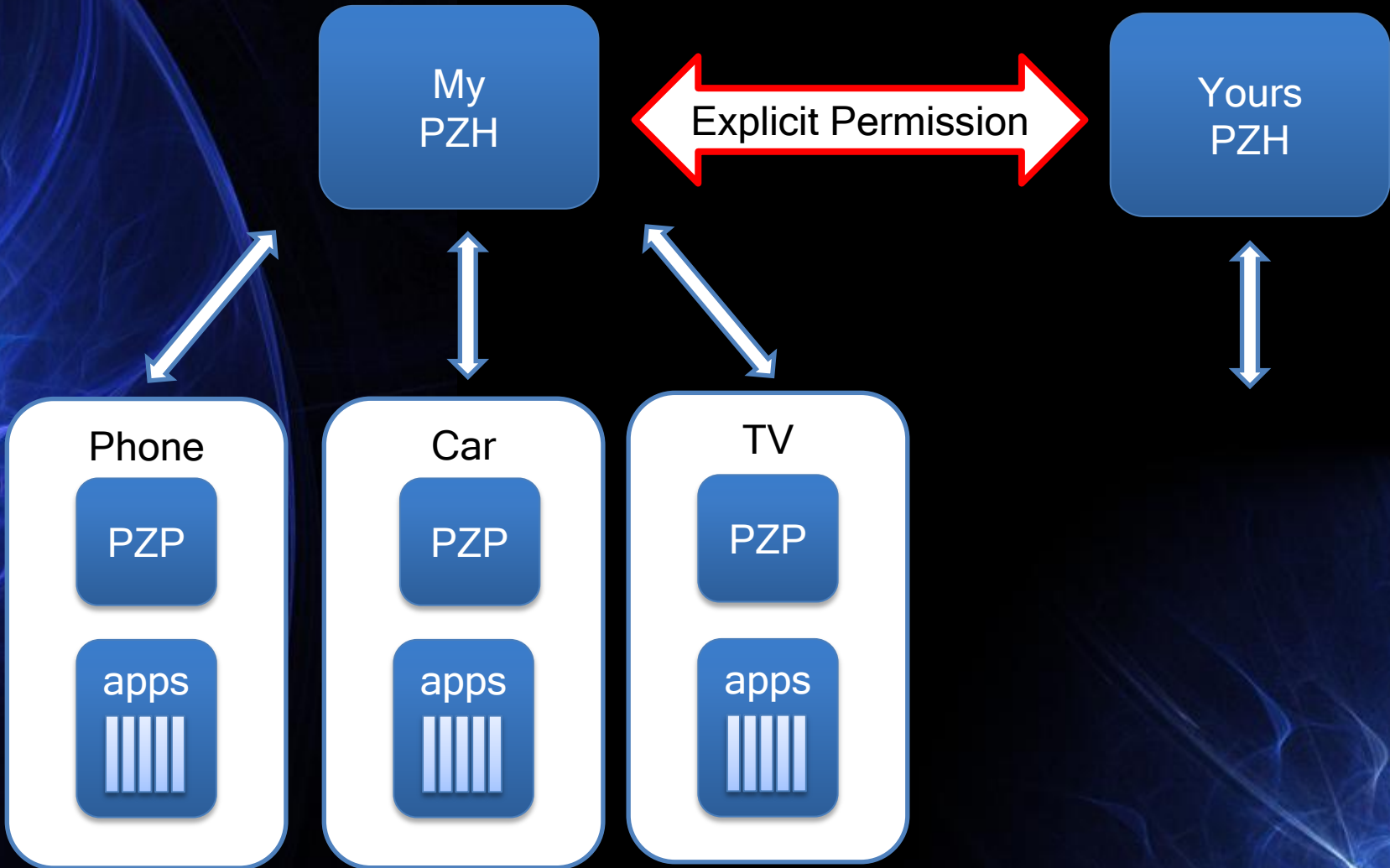

Webinos Architecture

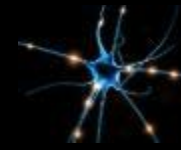

nquiringminds

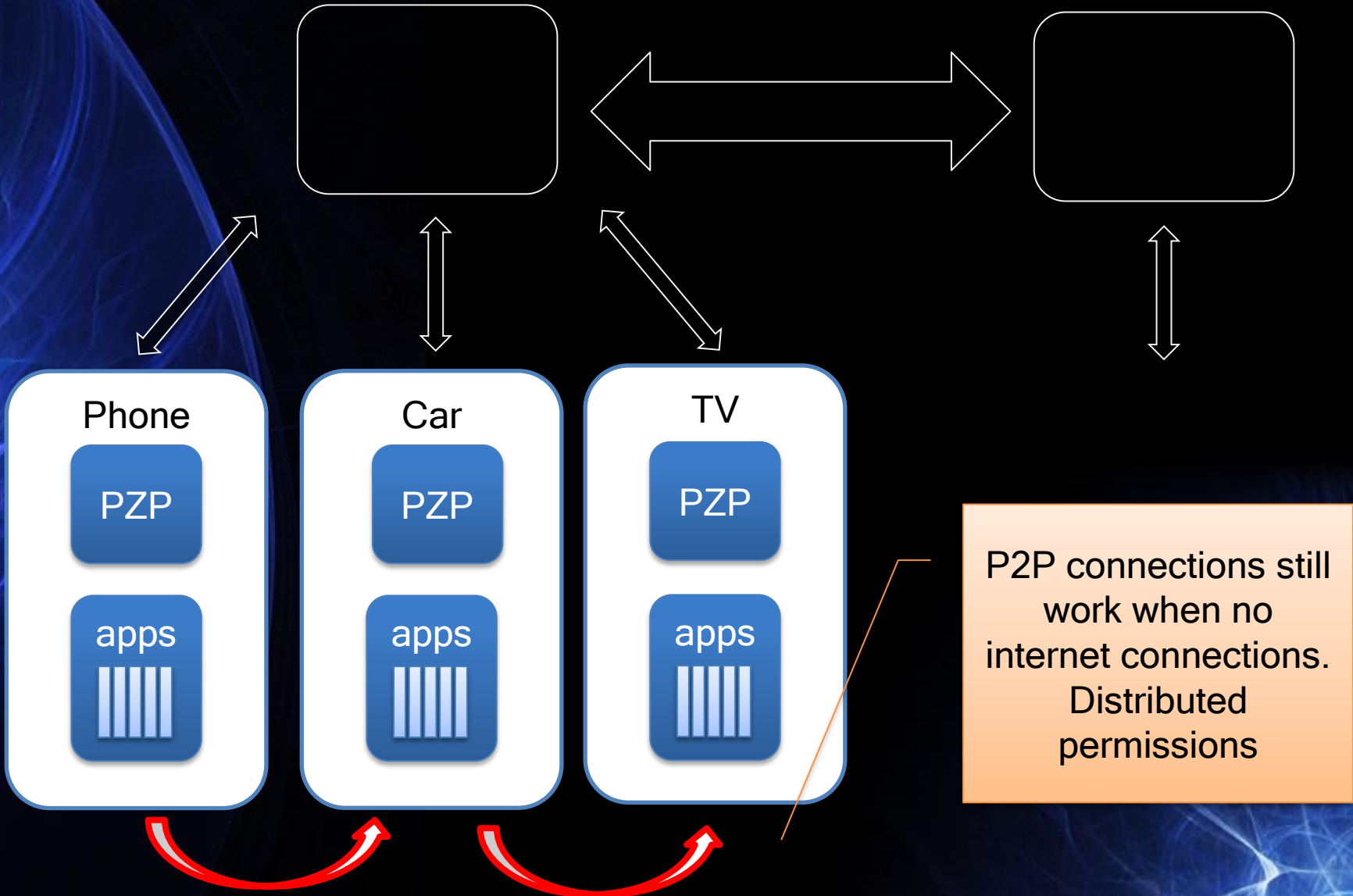

Webinos: Commercial model

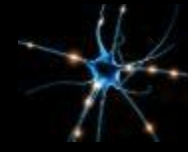

nquiringminds

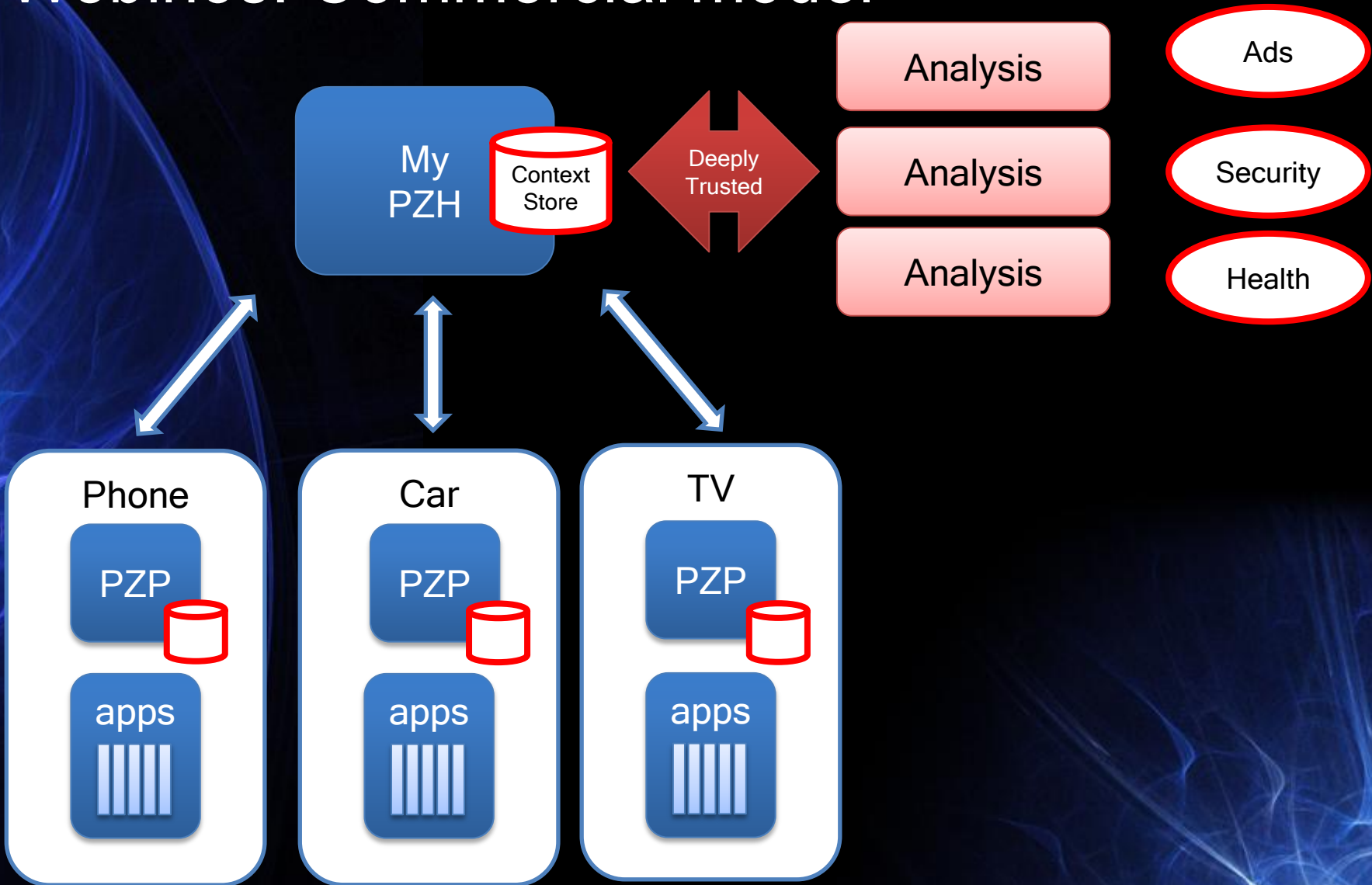



Summary

- Context requires many devices, many services working together:
 - Two challenges

Device Proliferation

OSS helps with market update
OSS helps with interoperability

Permission

OSS is (usually) vendor neutral
Needs to be user centric?
Needs to be universal

- Don't forget: <http://webinos.org/archives/979>